

1 2 3 4 5 6 7 8

REVISIONS		
ISS	ZONE	DESCRIPTION\PER REQUEST\DATE

業務部

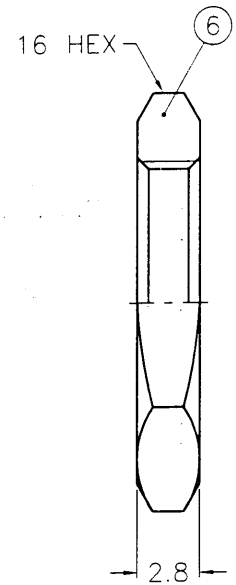
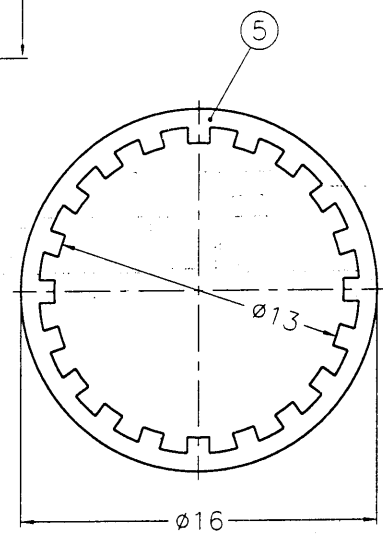
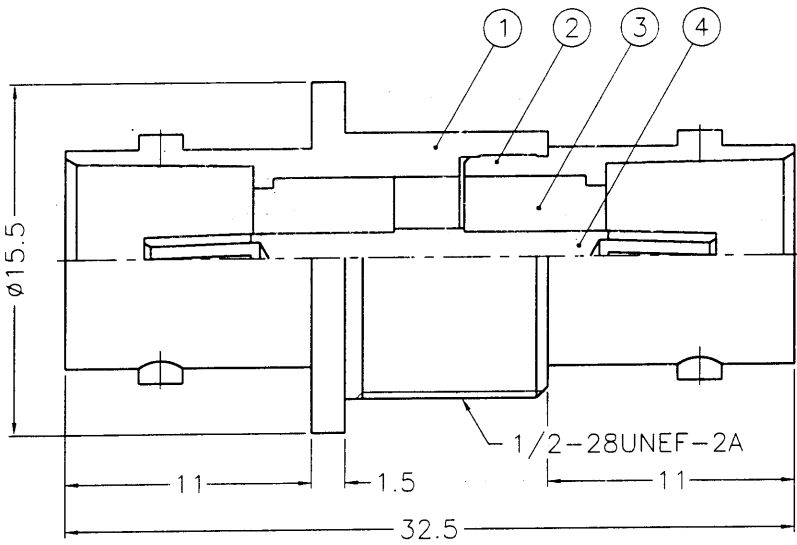
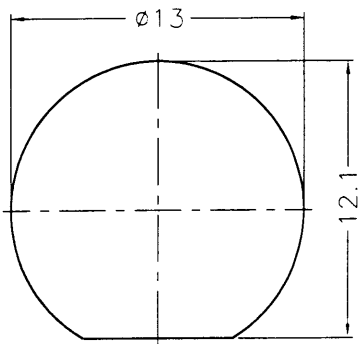

出圖
88.3.12

NOTES: FINISH (PLATING THICKNESS IN MICRO-INCHES)
 1. BRASS PER QQ-B-626
 2. BRASS PER QQ-B-613
 3. NICKEL PL. 100 MIN. THICK OVER COPPER STRIKE
 4. PHOSPHOR BRONZE PER QQ-B-750
 5. GOLD PL. 3 MIN. THICK OVER NICKEL PL. 100 MIN. THICK OVER COPPER STRIKE

NO.	DESCRIPTION	MATERIAL	FINISH	Q'TY	DRAWING NO.
6	HEX NUT	NOTE 1	NOTE 3	1	HN16-1/2-28X2.8
5	LOCK WASHER	NOTE 2	NOTE 3	1	LW-16/13X0.5
4	CONTACT PIN	NOTE 4	NOTE 5	1	B7900-4
3	INSULATOR	DELTRIN	NATURAL	2	B7996ZZ-3-75
2	BODY	NOTE 1	NOTE 3	1	B74000-2
1	HOUSING	NOTE 1	NOTE 3	1	B7915-1-A

DIMENSIONS ARE IN MILLIMETERS			
UNLESS OTHERWISE SPECIFIED TOLERANCES			
0.5-6	=	± 0.2	
6-30	=	± 0.4	
30-120	=	± 0.6	
120-315	=	± 1	
315-1000	=	± 1.6	
1000-2000	=	± 2.4	
SCALE	3/1	ISSUE	A

PART NO.	
APPROVED	DATE 03-10-99'
CHECKED	DATE 03-10-99'
DRAWN	DATE 03-10-99'

	KAI JACK INDUSTRIAL CO., LTD. TAINAN TAIWAN R.O.C.
TITLE	BNC FEMALE TO FEMALE BULKHEAD ADAPTOR
DRAWING NO.	KJ-B7471B1-ND3G-75
FILE NO.	F:\DWG\B\7471B1\75\ND3G

F
E
D
C
B
A

F
E
D
C
B
A

881 Rev 8/3